

DO NOT SCALE DRAWINGS  
BREAK ALL SHARP CORNERS UNLESS OTHERWISE SPECIFIED  
COUNTERSINK ALL TAPPED HOLES IN FINISHED SURFACES

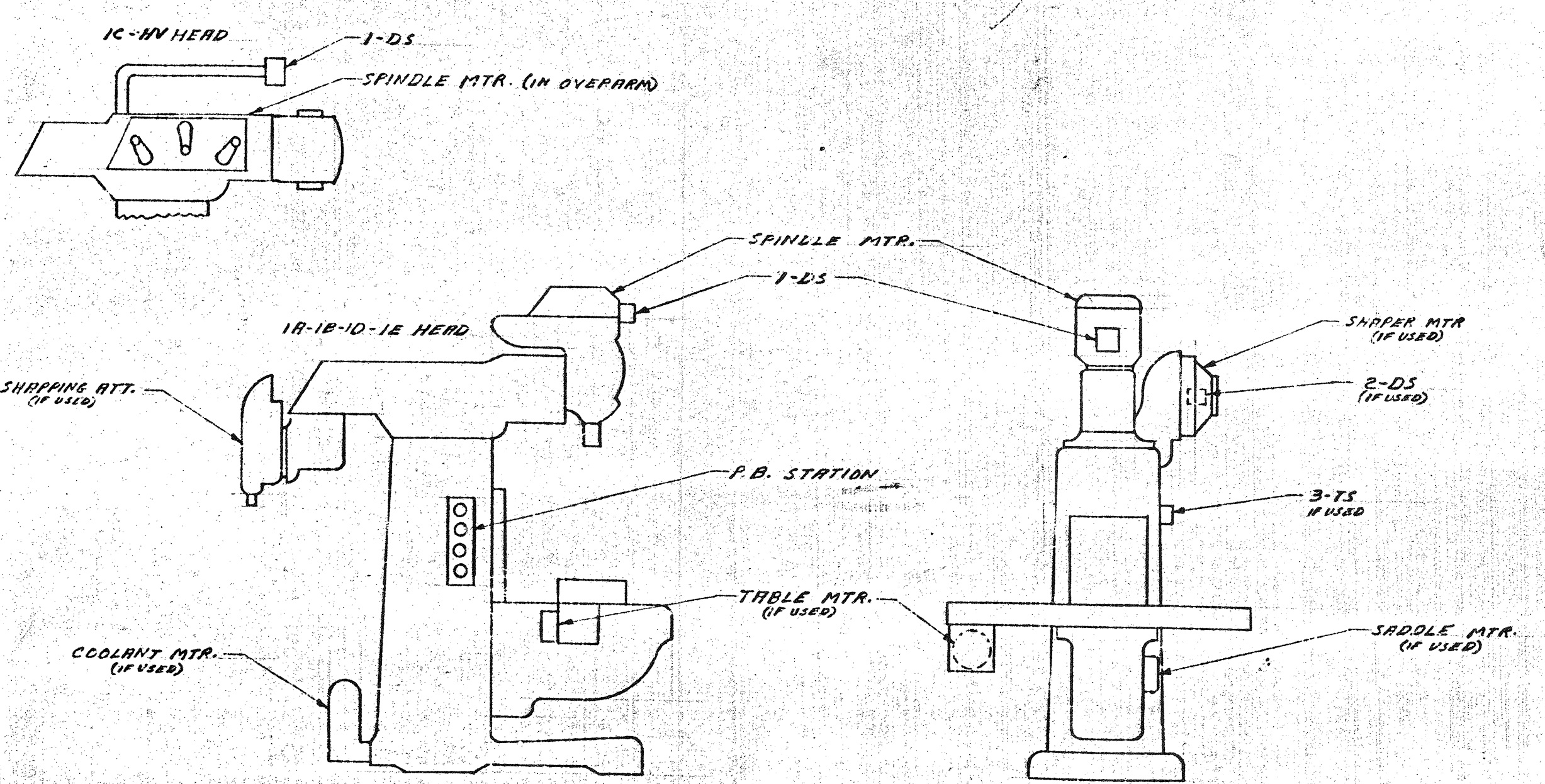
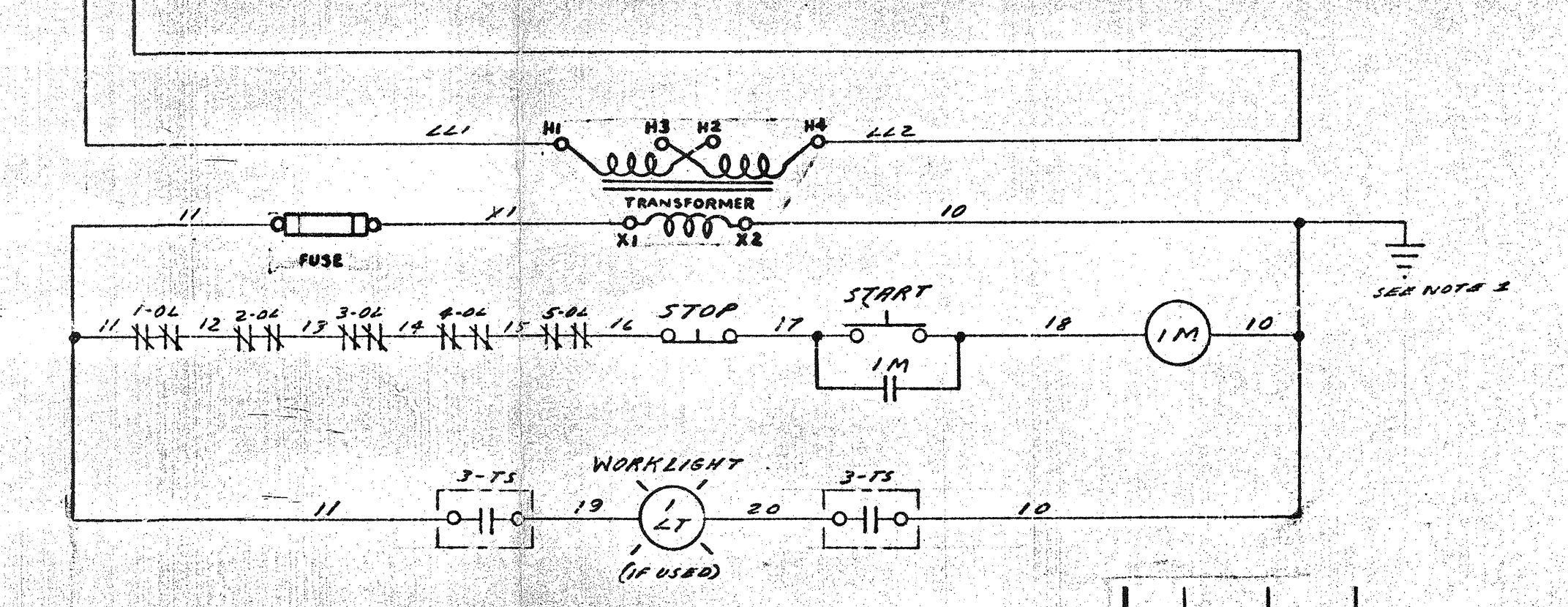
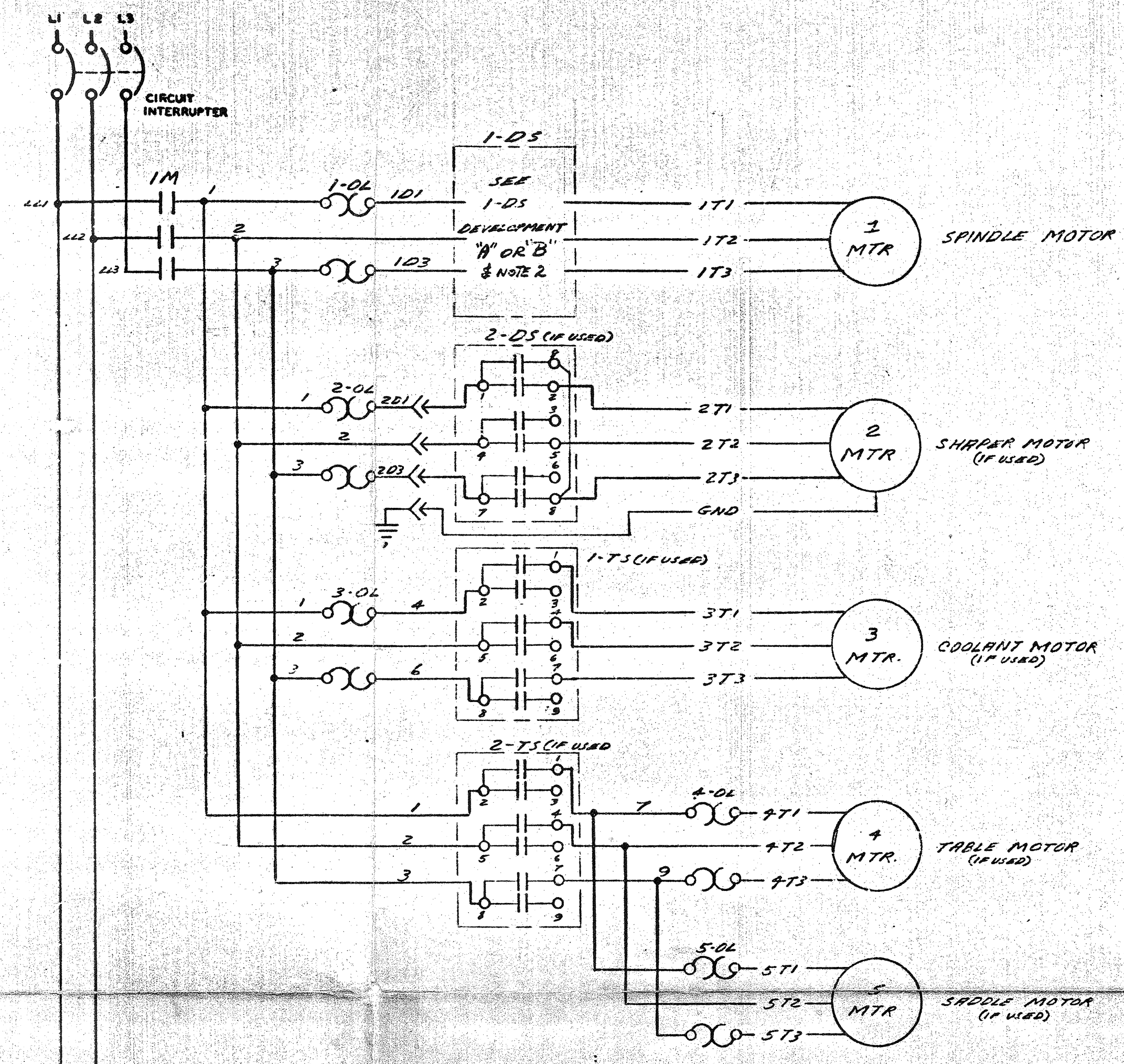
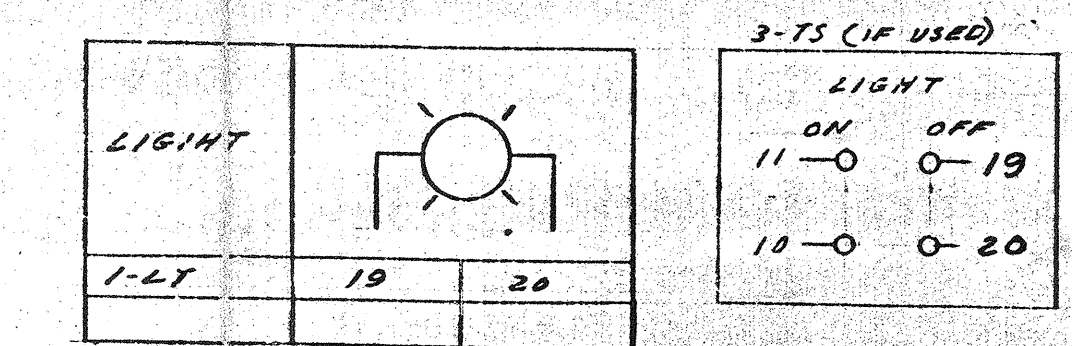
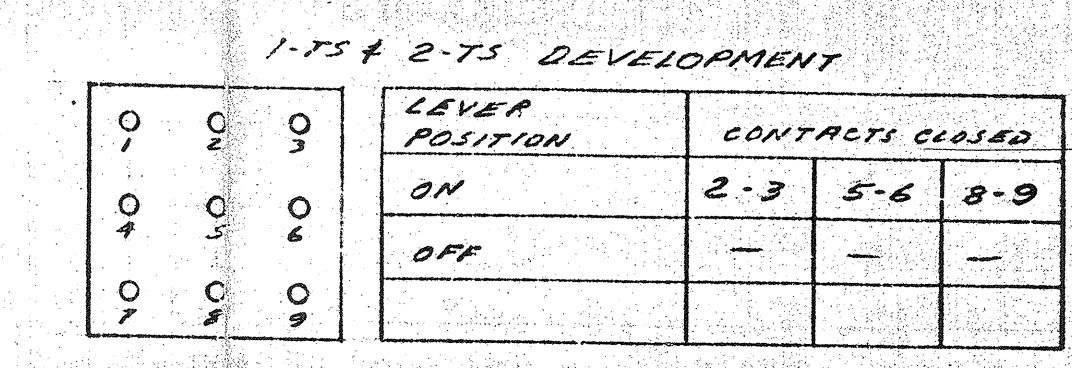
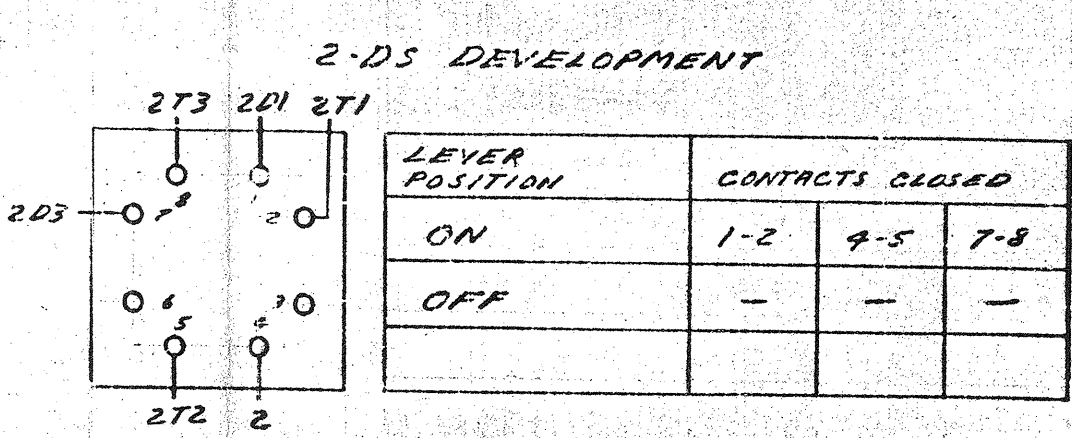
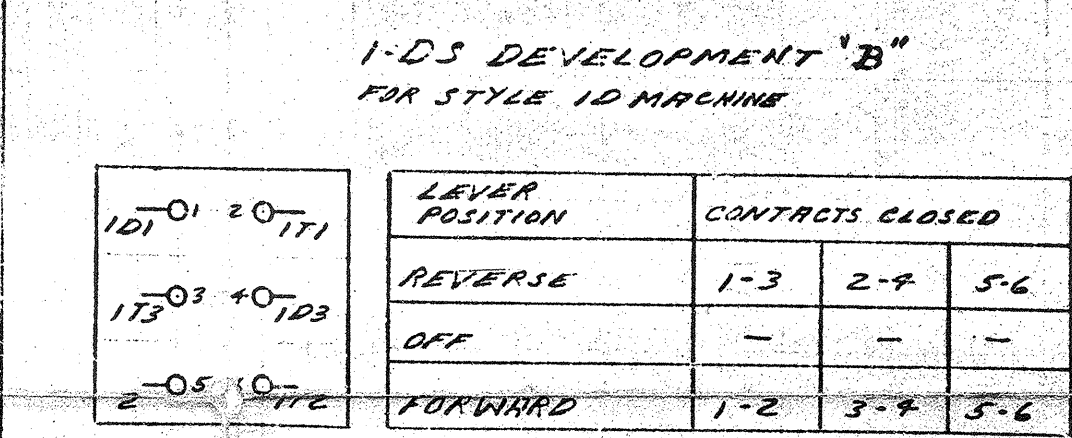
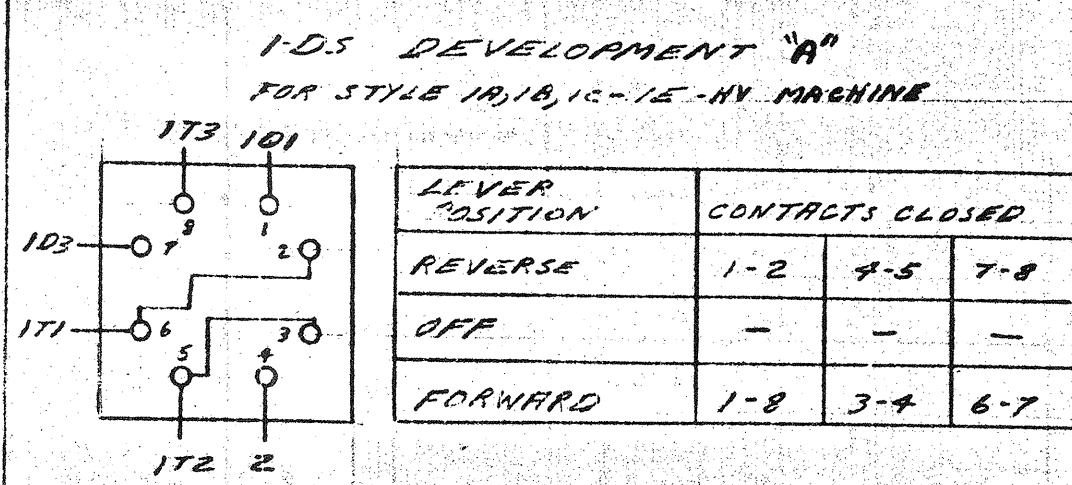
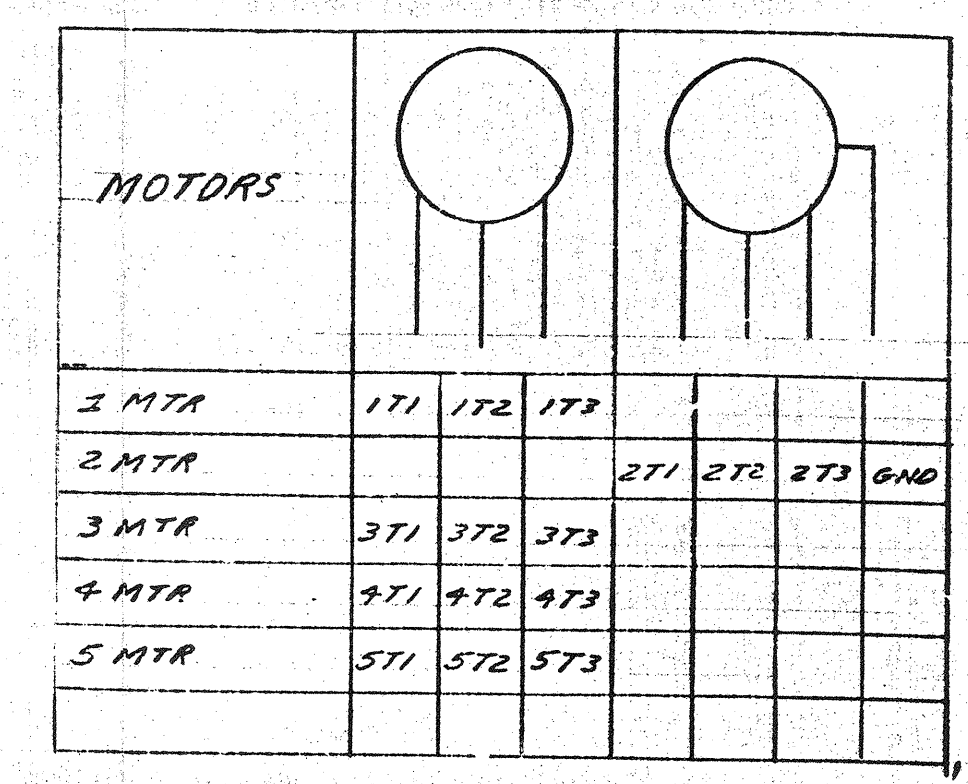
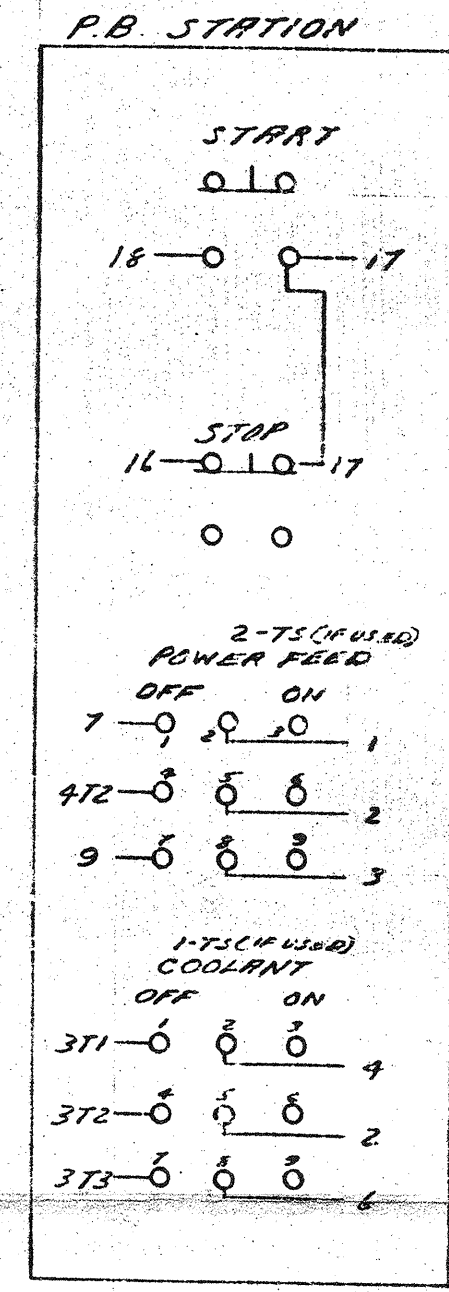
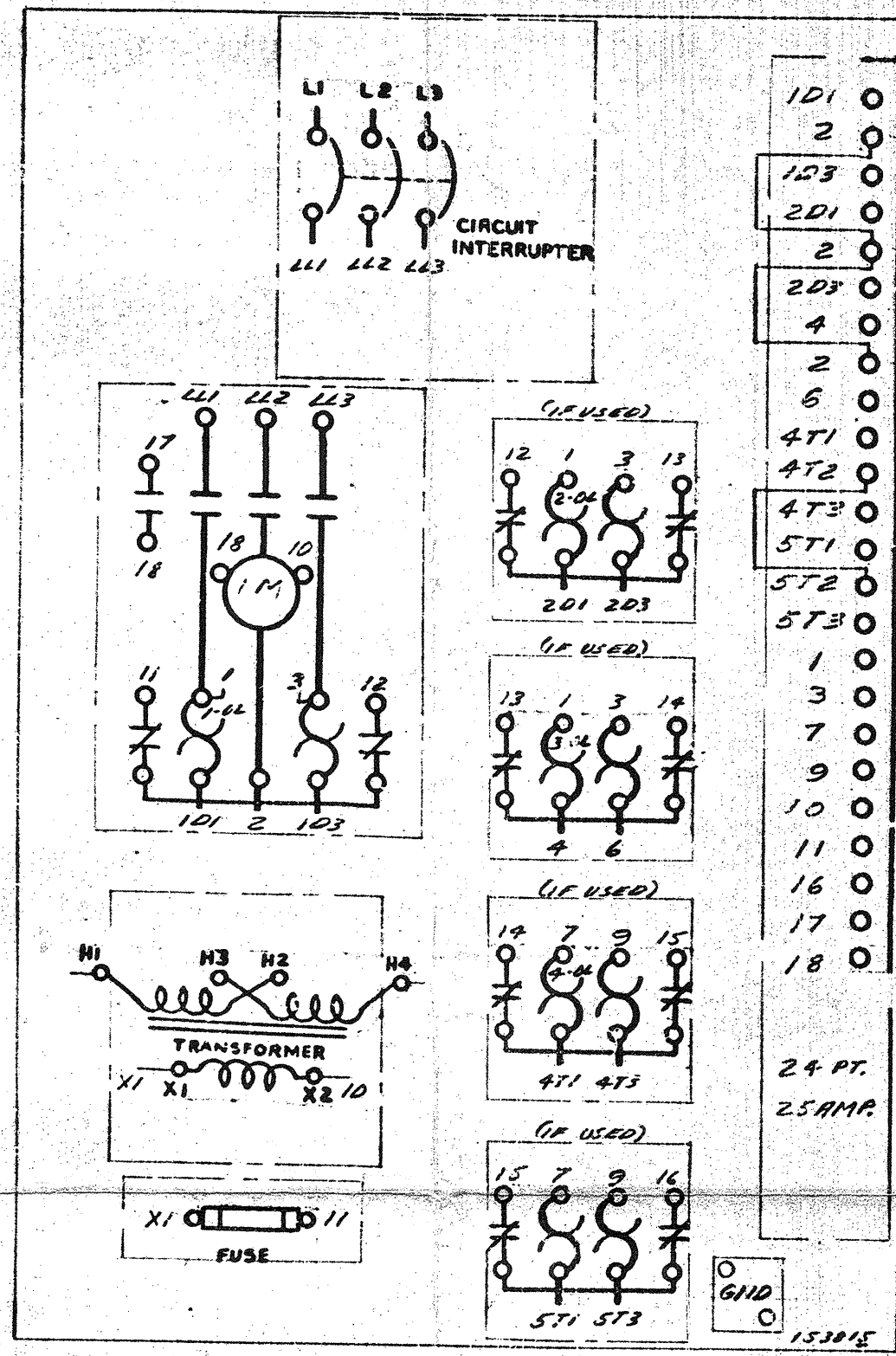

NOTE 1: MAY BE GROUNDED BY CUSTOMER IF CONDITIONS PERMIT  
NOTE 2: ADDED NEW STYLE DRUM SWITCH FOR 10-MACHINE. 10-MACHINE PREVIOUSLY USED SAME STYLE DRUM SWITCH AS 10-10-10-15 MACHINE FOR SPINDLE CONTROL (1-D5 DEVELOPMENT 'A')

ORIGINAL  
IN  
WILMINGTON

REV	DATE	BY	REASON
1	1-17-42	ADD'D NV MACH	
2	8-31-43	SEE NOTE 2	
3	8-31-46	ADD'D NEW STYLE DRUM SWITCH FOR 10-MACHINE	
4	4-13-57	REVISIONS	

LETTER	NOTICE	DATE	CHANGE
MACHINE	10-10-10-15-NV TOOLMASTER		
DRAWN BY	DATE	SUPERSEDED	
11-57	11-57	K-198-187	
DRAWN-CR BY	DATE	SUPERSEDED BY	

SHEET	1 OF 1	LAST NO.	20
<b>CONTROL DIAGRAM</b>			
ELEMENTARY & CONNECTION			
<b>B-176290</b>			
THIS CIRCUITRY IS THE PROPERTY OF THE CINCINNATI MILLING MACHINE CO.			